

# **NanoEiRei Summit**

**Honeywell – an increasing  
global presence in  
Industry, Research and  
Education**

April 2010

**Honeywell**

# Honeywell's Businesses

Honeywell

A Fortune 100 company – sales of \$30.9 billion in 2009

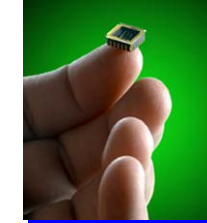
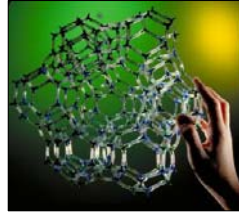

Specialty  
Materials

\$4.1B

Aerospace

\$10.8B



\$12.6B

Automation  
and Control Solutions

\$3.4B

Transportation  
Systems

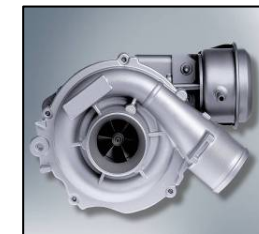
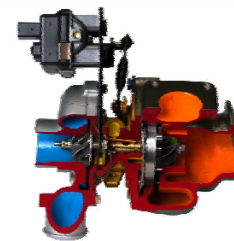

*Diverse Businesses, Technologies and Products*

## Honeywell's first initiative is Growth.

We pursue organic growth through four fundamental strategies, or “pillars”:

- Doing a superb job each and every day for our customers in quality, delivery, value, and technology
- Building a superior Sales and Marketing organization
- Globalization
- Creating a set of robust, funded technology roadmaps for new products and services

*Each Business Has Developed a Growth Game Plan*

# Honeywell Presence in Romania

**Honeywell**



# HONEYWELL ROMANIA

Honeywell

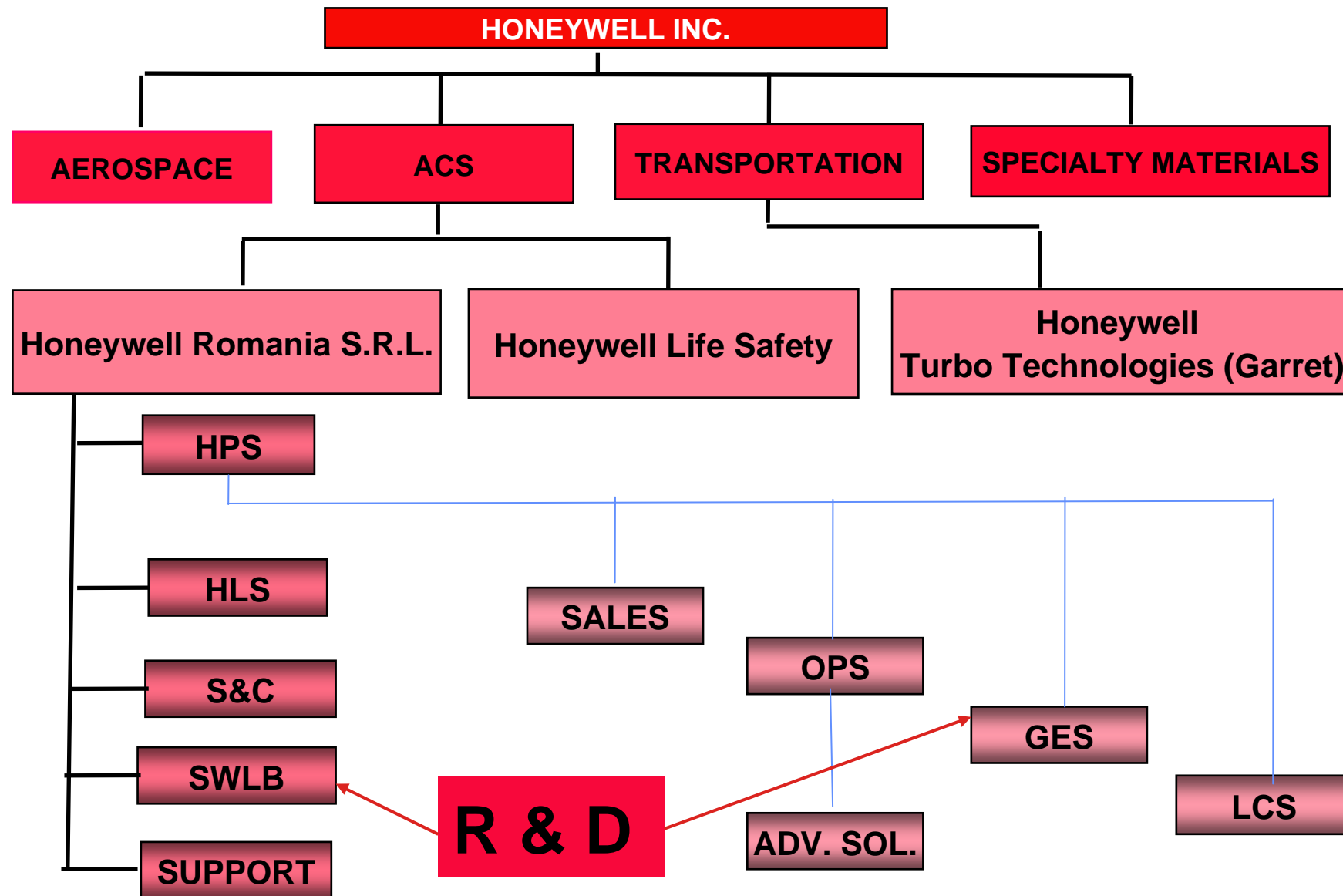

# ACS Overview

Honeywell

**Profile**

\$12.6B Revenue

More than 55,000 Employees

**Strengths**

- Large installed base
- Local customer relationships
- All are industry leaders
- Many diverse channels... OEM, retail, trade, consumer
- Key technologies drive growth

**Process Solutions**

**Building Solutions**

**Sensing and Control**

**ECC**

**Security**

**Life Safety**

Process Controls



Distributed Control



Buildings



Instant Alert



Speed and Position Sensors



Accelerometers



Pressure Sensors



Thermostats

Building Automation



Water Control

Gas Valves



Motion / Human Presence Sensors



CCTV/ DVR User Interfaces



Control Systems



Fire/Smoke Sensors



System Panels



Home Medical Care



*A leader in key segments ... Where technology wins*

# Honeywell ACS Labs - 4 Thrusts

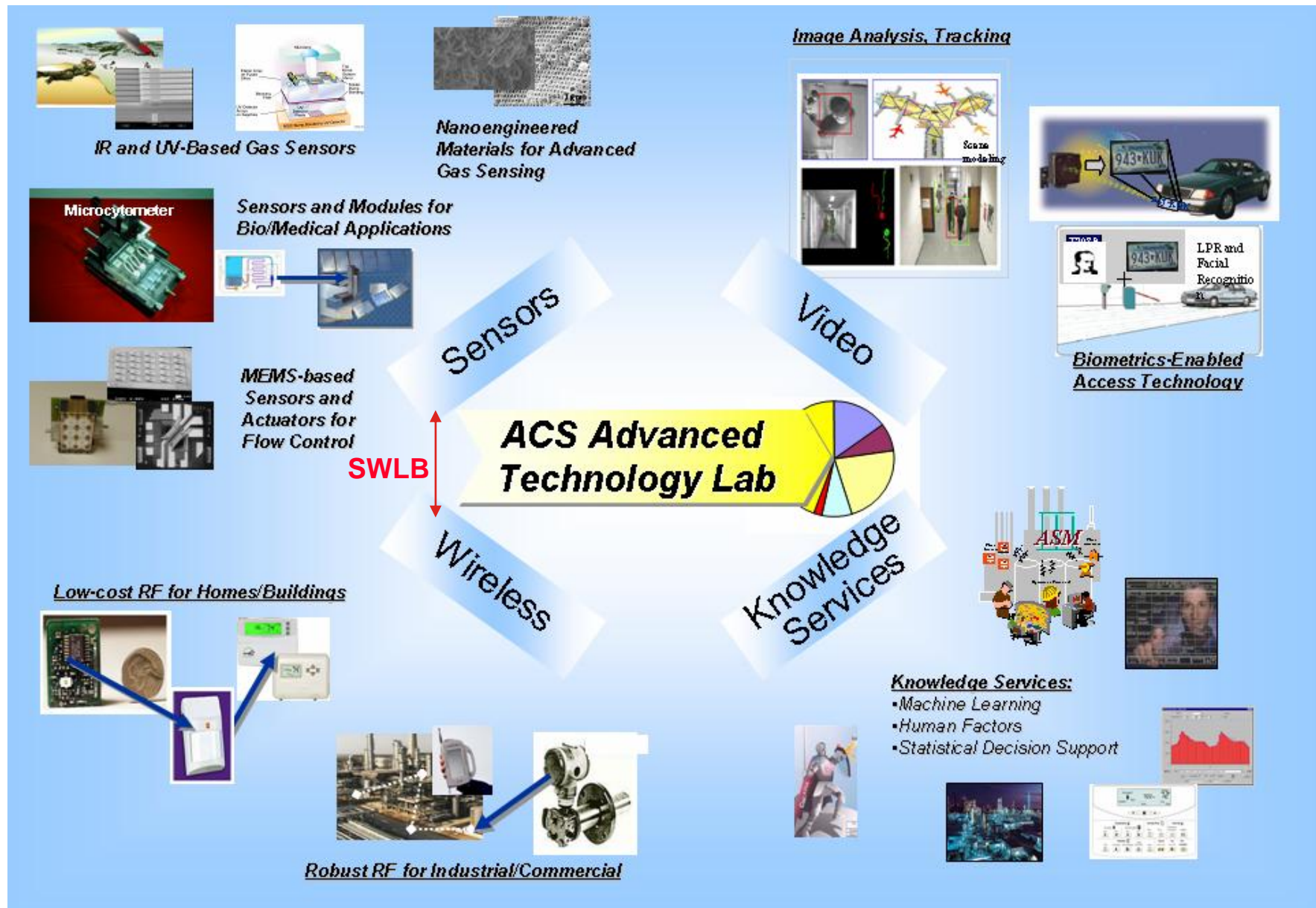

# ACS-Sensors & Wireless Global Labs

**Honeywell**

## **Minneapolis, MN**

- MEMS, Microsystems, Wireless, Nanotechnology
- US Government funded research programs
- Ties to top US universities

## **Bucharest, Romania**

- SAW, Nanotechnology
- EU/RO funded research programs
- Ties to top European universities

## **Bangalore, India**

- Wireless technologies research and development

## **Shanghai, China**

- Biomedical Sensors, Magnetics, Energy harvesting
- Ties to top Chinese universities

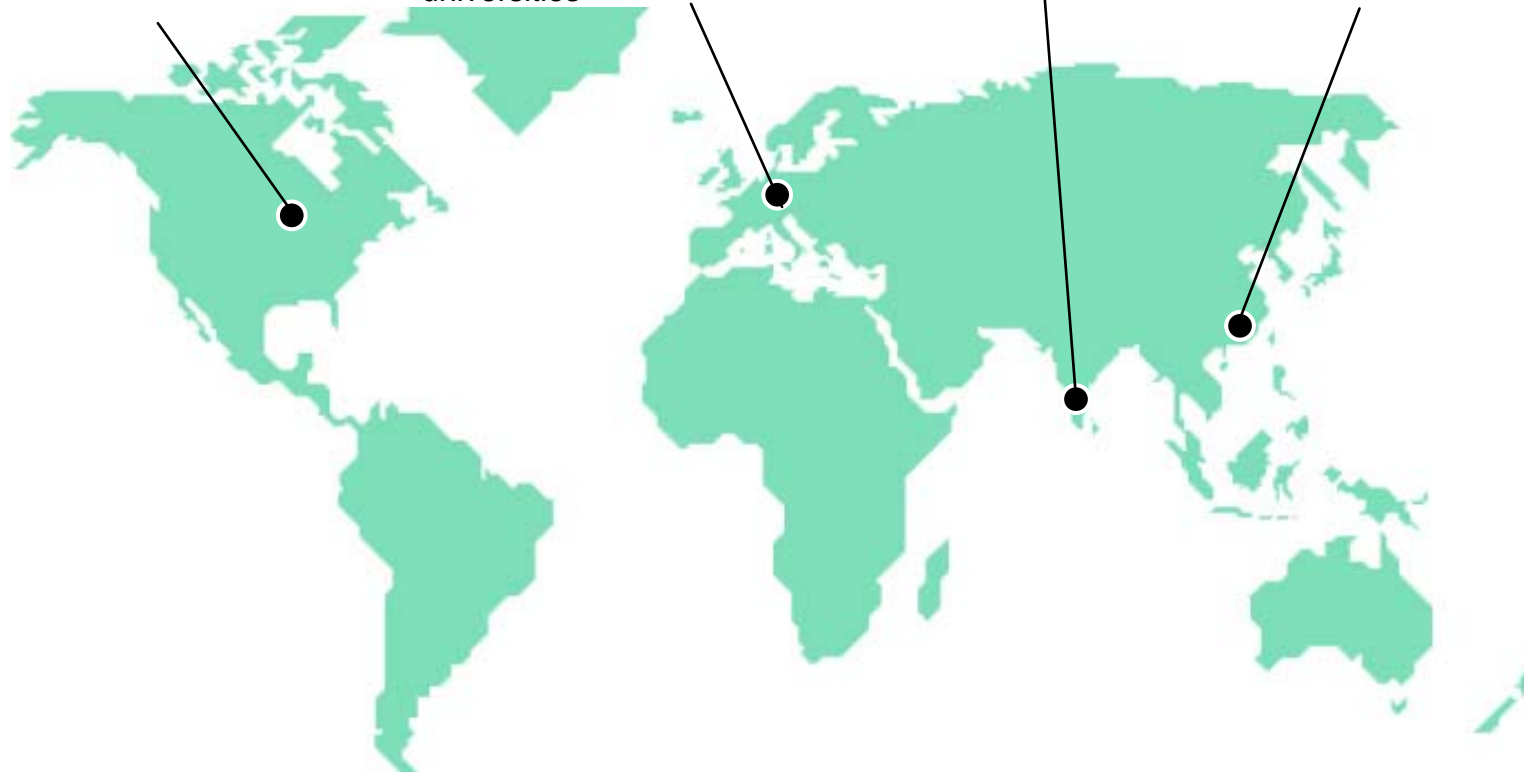

*Global talent developing next generation of sensors and wireless technologies for ACS*

**Honeywell Romania**

**Collaboration with Universities**

**Honeywell**

# Collaboration with Universities

Honeywell



BUCLRESTI - Institutul Politehnic



- Good cooperation with Romanian Association for Automation and Instrumentation (AAIR) and with Universities to increase industry involvement in the Academic programs;
- Graduation and MSc projects; training a number of selected engineers using Honeywell tools; internship during vacation.
- Sponsorship for: Oil & Gas University Ploiesti (Honeywell equipment and software); University of Bucharest (Physics); “Politehnica” University of Bucharest (Chemistry)
- Junior Engineers Training Program (JetPro) one-year graduate development program designed for junior engineers



# **Honeywell Romania**

**Accessing EU and Nat. Gov. funded  
R&D projects**

**Honeywell**

# Participation in EU projects - eCUBES

Honeywell

## *FP6 - IP project (2006-2009) - Completed*

- 3-D-Integrated Micro/Nano Modules for Easily Adapted Applications
- next generation wireless autonomous systems
- Infineon, NXP (Philips), Thales, Honeywell and several academic EU organizations

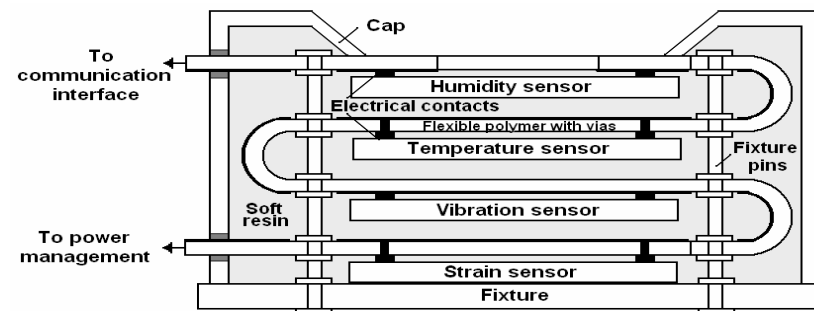

SHCMA chips/sensors mounted on a flexible polymer tape

**EU programs - excellent opportunity for public-private research partnership in Europe**

# Participation in EU projects - NEMSIC

Honeywell

## ***FP7 - STREP project (2008-2011) – On-going***

- Hybrid Nano-Electro-Mechanical IC Systems for Sensing and Power Management Applications
- No. 1 out of 160 proposals at the nanotechnology section
- Nanomaterials synthesis for gas sensing

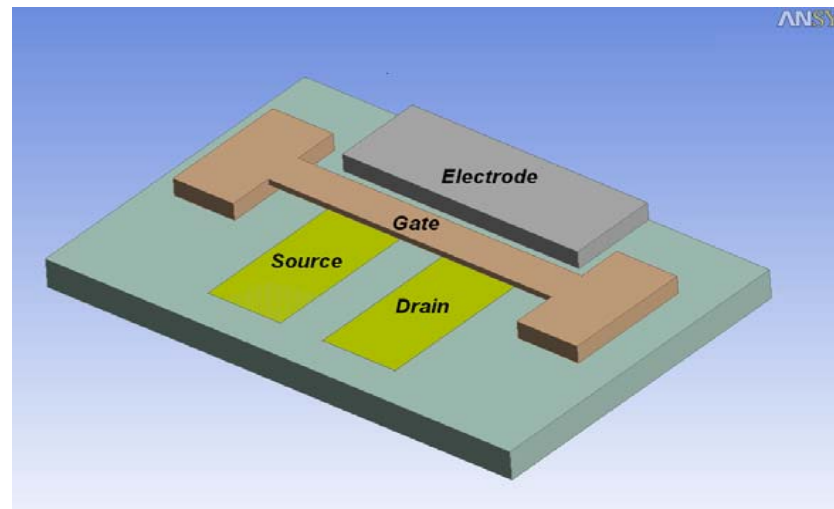

**EU programs - excellent opportunity for public-private research partnership in Europe**

# Participation in RO Structural projects - NOVOCELL

Honeywell

## **SOP – IEC (2010-2013) – To start soon**

(Complex research projects fostering the participation of high-level international experts)

- Nano-photovoltaic Solar Cell;
- Dye Sensitized Solar Cell using organic hyperpolarizable molecules (HM) as photon absorbers (chromophores);

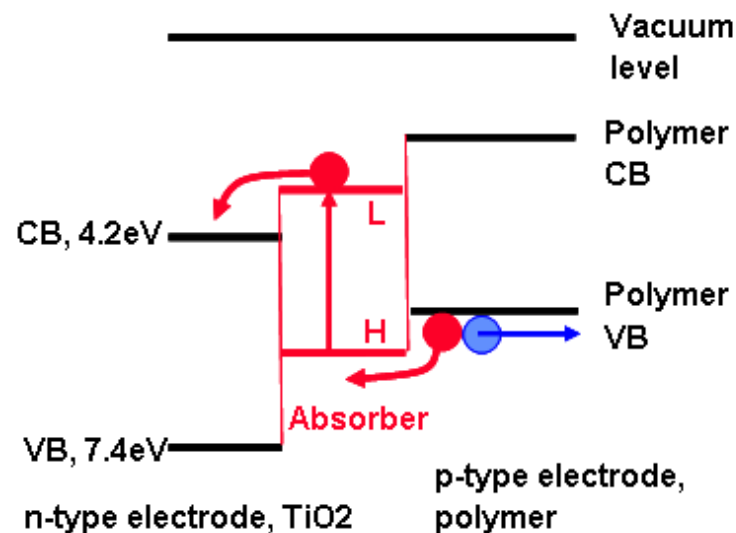

**Romanian Structural funding - excellent opportunity for public-private research partnership in Romania**

# Participation in RO Structural projects - VIPRES

Honeywell

## **SOP – IEC (2010-2013) – To start soon**

(Complex research projects fostering the participation of high-level international experts)

- Vibration/Pressure Sensor for Industrial Asset Monitoring;
- Low cost-high sensitivity vibration sensors/arrays integrating the piezoelectric materials with thin film transistors (FET) or nanowires-field effect transistors (NW-FET);

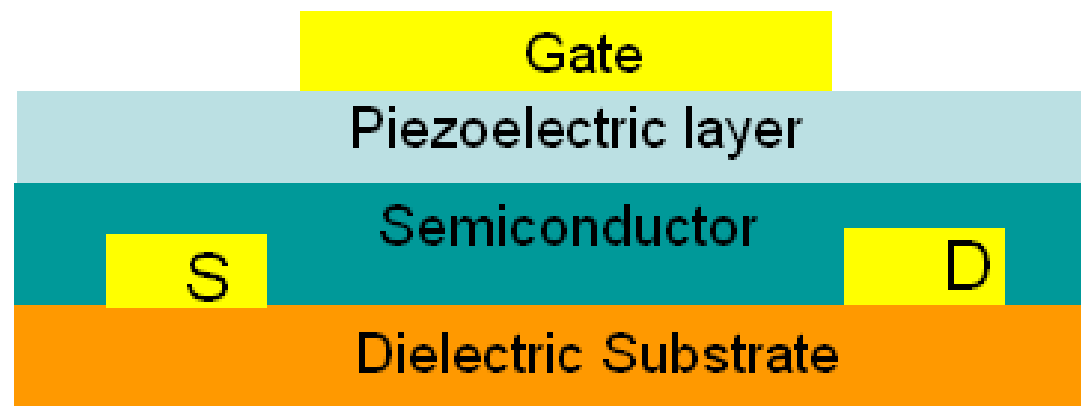

**Romanian Structural funding - excellent opportunity for public-private research partnership in Romania**

**Honeywell Romania**

**Partnerships with R&D Institutions**

**Honeywell**

# Honeywell Romania – Collaboration with R&D Institutes

Honeywell

- **Joint submission on EU and RO funded research projects:**
  - HITSENZ (High Temperature Sensors) Project Proposal: submitted in February 2008;
  - Consortium: HON, INCDFM (National R&D Institute for Materials Physics), ICF (Romanian Academy Institute for Physical Chemistry), UPB (University “Politehnica” Bucharest)
- **Strategic Partnership with IMT Bucharest (National Institute for R&D in Micro-technologies) on:**
  - Joint EU/RO funded projects;
  - Access to technological facilities;
  - Agreement on IP issues;
- **Partnerships for technological services (including new developments):**
  - INCDFM,
  - ICF,
  - METAV SA

## R&D

- **Nano-sensing principles and systems;**
- **Nano-materials;**
- **Modeling and Simulation;**
- **Packaging;**
- **Testing.**

*“Giga” interest in the Nano World*

# How do we see the future?

- **A closer relationship between Industry and Academia; focus the education on what industry sees as their needs – for present and future; consider direct contact with both Companies and professional Associations for feedback and guidance;**
- **How do we align business (strategically) plans with (future) R&D National Plans?**
  - **A bi-directional flow of information;**
  - **Consulting Industry on Strategic R&D National Plans;**
- **Accessing R&D funds; better alignment with EU FP7 rules could make things go smoother and more efficient (overall)**
  - **Increase transparency;**

**Thank you for your attention!**