

Carbon-based nanomaterials. Environmental applications

Alina Catrinel Ion, Ion Ion, Alina Culetu

University Politehnica of Bucharest, Department of Analytical Chemistry and Instrumental Analysis, Polizu street no. 1-7, 07113, Bucharest, Romania
e-mail: ac_ion@yahoo.com

Abstract: In this review, environmental and agricultural applications of carbon-based nanomaterials, natural and engineered as possible environmental sorbents will be presented. The rather new applications of engineered carbon-based nanomaterials as sorbents for organic and inorganic contaminants in soil systems will be emphasized, as well as the behavior of natural carbon-based nanoparticles in soils. Possible enhancement of several organic and inorganic substances sorption through these nanoparticles in soils has to be regarded as well. A correlation between the type and amounts of nanoparticles in soils and the amounts of chemical substances delivered or retained have to be re-evaluated in the future.

Introduction

Nanotechnology is defined as understanding and control of matter at dimensions between 1 and 100 nm, where unique phenomena enable novel applications.¹ The application of nanotechnology to the environment and agriculture was addressed by the United State Department of Agriculture in a document published in September 2003², rapidly evolving and revolutionizing the agriculture. Nanotechnology can play an important role in pollution sensing through surface-enhanced Raman scattering, surface plasmon resonance, fluorescent detection, electrochemical detection and optical detection, treatment through adsorption, photocatalysis treatment of pollutants, reduction by nanoparticles and bioremediation.

The implications of the nanotechnology research in the environment and agriculture are developed based on the identification of the nanoresearch thematic areas of relevance to the environmental and agricultural system. Nanomaterials like: nanoparticles, carbon nanotubes, fullerenes, biosensors, controlled delivery systems, nanofiltration find relevant applications in agri-food thematic areas like: natural resources management, delivery mechanisms in plants and soils, use of agricultural waste and biomass, in food processing and food packaging, risk assessment being also evaluated.

Nanosensors in the environment and agriculture begin to have wide applications due to the **environmental monitoring** of pollutants present in the atmosphere, in soils and in wastewater. Different categories of sensors are used like: biosensors, electrochemical sensors, optical sensors. The nano-detection sensors and devices will be the main instruments for trace heavy metals and POPs detection and these can be applied to real samples, the need of commercializing nanosensors becoming in the next years a necessity.

In **treatment** applications, conventional water treatment methods include bio-sand, coagulation, flocculation, reverse osmosis, distillation and adsorptive filtration through ion-exchange resins, active alumina or iron oxide cannot remove all the contaminants. Widely used sorbents for water treatment include: nano-structured metal oxides, carbon nanomaterials, zero-valent iron nanoparticles. Nano iron oxides are well known for removing of toxic ions and organic pollutants from water^{3,4,5}. Carbon nanostructures have been studied because of their physical and chemical properties and their applications, presenting high capability for the removal of various inorganic and organic pollutants and

radionuclides from large volumes of wastewaters. Heavy metal ions were removed from aqueous solutions being adsorbed on the surface of the oxidized carbon nanostructures^{6,7}. The adsorption isotherms show that different kinds of heavy metals have different affinity to the adsorbent depending on the material. Surface nano-scale modified carbon black present good affinity for Cu(II) and Cd(II) and Fe⁰ nanoparticles for As(III) in groundwater.⁸

Another application of nanomaterials in environmental and agricultural treatment is the **remediation** (pollutant transformation from toxic to less toxic in water and soil). Researchers have focused their attention on the remediation of water and soil using Fe⁰ nanoparticles which can transform the pollutant (chlorinated organic chemicals) without leaving the chlorinated intermediate by-product.^{9,10} Fe⁰ nanoparticles were already applied in the reduction of PCB¹¹, in the reductive debromination of diphenyl ethers¹², in the removal of alachlor and pretilachlor¹³ and catalysis of chlorinated ethenes.¹⁴ Simultaneous dechlorination of several pollutants is important for agriculture applications¹⁵, as well as the exploration effective reduction nanoparticles¹⁶ other than Fe⁰ and bimetal nanoparticles for metal removal.¹⁷

Nanosorbents are very important for capturing heavy metal ions and organic contaminants.

A smart application of carbon nanomaterials for the removal of heavy metals from soils is also emphasized.¹⁸ The encapsulation of carbon nanotubes to form a reconfigurable conglomerate with iron oxide microcapsules and their applications in Pb(II) removal was achieved, proving to be recyclable and environmentally friendly for the removal of heavy metals.

Photocatalysis in agriculture is another direction in which nanomaterials can play an important role. Different nanostructures of titanium dioxide (TiO₂) and zinc oxide (ZnO) have been widely studied as photocatalysts.^{19,20} Methylene blue adsorbed on the surface of ZnO nanoparticle degrades it into leucomethylene blue²¹, chemicals presented in pesticides are transformed in relatively harmless molecules such as CO₂, N₂ and H₂O. Under progress is also the removal of pesticides and herbicides on plants and the soil through photocatalysis.²² Carbamate pesticides used in a variety of field crops are completely mineralized in the presence of ZnO and TiO₂, dichlorvos being an example of an often used pesticide. Apart from nanoparticles, there are reports on the use of nanotubes and nanostructures thin films for degrading pesticides. TiO₂ nanotubes were used for atrazine degradation²³ and TiO₂ thin films for the degradation of organochlorine pesticides.²⁴

Nanomaterials are (taking into account healthy aspects of nanotechnology) quite effective in detection and treatment systems of environmental pollutants. **Developing functional properties of nanomaterials** trace detection of inorganic and organic pollutants and treatment in water and soil can be tremendously improved. Nanomaterials can be used to detect pesticides, to selectively capture target pollutants and to treat them through reduction or oxidation operation of the nanomaterials. Through **the synergetic action of nanomaterials and through biological processes**, pollutants can be also removed, this methods being used in the environmental engineering of water and soil. Through **nano-photocatalysis** the removal of pollutants becomes another very important direction in environmental engineering, especially in treating pollutants form industrial areas.

In this review, environmental and agricultural applications of carbon nanomaterials, natural and engineered as sorbents will be presented. These materials unite the properties of sp² hybridized carbon bonds with the characteristics of physics and chemistry at the nanoscale. The most common properties cited in environmental applications are size, shape and surface area, molecular interactions and sorption properties and electronic, optical and thermal ones.

Properties of carbon-based nanomaterials

Molecular manipulation implies control over the structure and conformation of a material, for carbonaceous nanomaterials this including size, length, chirality and the number of layers. Variations in synthesis technique, temperature, pressure, catalyst, electron field optimize nanomaterial structure, purity and physical orientation for specific applications.²⁵ Diameter is an important dimension in determining the properties and applications of tubular carbon nanostructures. Small single walled carbon nanotubes (SWNT) diameter is strongly correlated to synthesis technique²⁶, the diameter inducing higher strain energies, mixing of σ and α bonds and electron orbital rehybridization. These bond structure modifications induce fundamental alterations to the electronic, optical, mechanical, elastic and thermal properties of SWCNTs. The characteristic properties dependent on nanotube diameter are complemented by physical size exclusion and capillary behavior relevant to environmental and agricultural systems. The narrow inner diameter of nanotubes has found application in novel molding, separation and size exclusion processes.²⁷ The combined characteristics of narrow diameters and long tubules also imply exceptional aspect ratios in nanotubular structures.²⁸ Across the spectrum of carbonaceous nanomaterials, the high surface area to volume ratio distinguishes nanomaterials from their micro-scale counterparts. The ratio of $\Delta G_{\text{surface}}/\Delta G_{\text{volume}}$ increases, where ΔG represents the difference in free energy between the bulk material and the nanoscale structure.²⁹ The size, shape and surface area of carbonaceous nanomaterials are highly dependent upon aggregation state and solvent chemistry. Impurities adsorbed to the surface of nanomaterials alter the aggregation behavior, thermal and electron characteristics, mechanical strength and physico-chemical properties of the nanomaterials.

Electronic, optical, thermal properties The bonding configuration of carbon based nanomaterials confers unique conductive, optical and thermal properties for applications in the electronic industry. Novel electronic properties will contribute to environmental sensing devices and to new environmental remediation techniques of persistent organics.³⁰ Tunable band gaps, remarkable stable and high-current carrying capacity, low ionization potential and efficient field emission properties³¹ are highly cited electronic properties of SWCNTs, these properties being linked to chirality, diameter, length and the number of concentric tubules. Theoretical and experimental work demonstrates that band gaps are dependent upon the chirality and diameter of nanotubes. A reference coordinate system indexes the chirality of the SWCNTs by a pair of (n,m) integers corresponding to the specific atoms on a planar graphene sheet.³² Armchair conformations denoted by (n,n) tubes are metallic and independent of tube diameter and curvature. The (n,m) nanotubes with carbon atoms arranged in a zigzag or helical conformation are small gap or large gap semiconductors. Conduction in MWCNTS is dominated by the electronic structure of the outermost tubules and resembles the electronic behavior of graphite.³³

The ionization potential of SWCNTs is below of common field emitters used in the electronic industry, the ionization potential referring to the energy necessary to excite an electron from the ground state to an excited state. In field emitters, a low ionization potential reduces the voltage necessary for exciting an electron and forcing its emission from the molecule. Further reduction in ionization potential is observed in the presence of certain adsorbates, including water. Reducing the voltage potential and enhancing the efficiency of field emission is an example of nanotube application in the green design of next generation devices.

Molecular interaction and sorption Elucidating the molecular interactions, sorption and partitioning properties governing carbon based nanomaterials is generally consistent with physical-chemical models and theories including electrostatics, adsorption, hydrophobicity, etc...Molecular modeling can provide explanations about physical-chemical processes at the nanoscale. The potential

energies of interaction between carbonaceous nanomaterials are already described in the literature³⁴, accounting for both van der Waals attractive forces and Pauli repulsion originating from overlapping electron orbitals at short separation distances. Hydrophobicity and capillarity will contribute to the adsorption behavior and orientation of sorbates in microporous carbon, physisorption being the dominant mechanism of sorption for not functionalized nanomaterials. Adsorption studies report rapid equilibrium rates, high adsorption capacity, low sensitivity to pH range, minimal hysteresis in dispersed nanoparticle sample³⁵ and consistency with Langmuir, BET or Freundlich isotherms.³⁶ These studies are complicated by the unique properties of adsorption in micropores. In environmental applications, adsorptive capacity has broad implications for contaminant removal and hydrogen storage.

Sorption of environmental contaminants to sorbents such as NOM, clay and activated carbon accounts for an important sink in natural and engineered environmental systems. The sorptive capacity of conventional carbonaceous sorbents is limited by the density of surface active sites, the activation energy of sorptive bonds, the slow kinetics and the nonequilibrium of sorption in heterogeneous systems. The large dimensions of traditional sorbents also limit their transport through low porosity environments and complicate the subsurface remediation. Carbonaceous nanosorbents with their high surface area to volume ratio, controlled pore size distribution and their surface chemistry overcome many of these intrinsic limitations.

An integration of innovative use and existing knowledge and technologies in agriculture with nanotechnology and innovative partnerships between agricultural research institutions with nanoscience research institutions and universities and nanotech companies will help nanotechnology to be faster and efficient applied in agriculture.

Nanotechnology and the environmental soil science

Soil science is concerned with the science of all those materials we find in soils, this being a complex mix of chemicals and organisms some of which are organized at the nanolevel and some of which are not. The thorough analysis of natural nanoparticles (NPs) and engineered NPs in soils involves the sequence of detection, identification, quantification and detailed characterization, if possible. To study and to understand the properties and behavior of different size fractions in soils is a difficult task, each size fraction of the soil matrix, the colloidal fraction, the clay fraction, the slit fraction, the sand fraction and the gravel having specific properties and roles within this matrix. The nano fraction in soils can prove to control or to affect the soil physical or chemical properties, the understanding of the nanomaterials behavior being far from complete from the physical chemistry point of view.

Natural nanoparticles in soils may occur as **nanominerals** e.g. certain clays and Fe and Mn oxyhydroxides or as **carbon containing** NPs.^{37, 38} Soils and sediments contain many kinds of inorganic and organic particles such as: clay minerals, metal hydroxides and humic substances³⁹, nanoparticulate goethite, akaganeite, hematite⁴⁰, ferrihydrite and soil humic substance.⁴¹ Hochella⁴² classified the NPs present in terrestrial systems in three classes: nanofilms, nanorods and NPs. Nanosheets are usually products of the weathering processes that occur in soils, having very diverse compositions (usually mixtures of oxides and oxyhydroxides of Fe or of other elements).⁴³ Nanorods result usually in the process of accelerated weathering of primary soil minerals induced by sediments at alkaline pH values, nanosize hematite and feldspaths appearing.^{44, 45, 46} Nanoparticles (NPs) found in soils can be biogenic uraninite⁴⁷, oxidized iron formed by biologically induced oxidation of Fe(II)⁴⁸, Fe(III) oxyhydroxides NPs which can constitute the ferric core of ferritin, the main iron storage protein in biological

systems.⁴⁹ As Hochella et al. has already shown⁶, ferrihydrite in natural sediments behaves as a natural sorbent, but its structure and composition is still a matter of debate.

The organic nanomaterials in soils (considered by Nowack and Buchelli as carbon-containing natural NPs)⁵⁰ are divided into biogenic, geogenic and pyrogenic NPs. Examples of natural NPs are fullerenes and carbon nanotubes (CNTs) of interstellar origin⁵¹. Environmental colloids in soils include humic substances and large biopolymers such as polysaccharides and peptidoglycans and even the knowledge of their structures increased in the last years, their precise function and composition is not very well defined.⁵² Soot as product of re-condensation processes during incomplete combustion of fossils appears in soils and in the atmosphere, where from it is again deposited on soils.⁵³ Some of them can derive from polycyclic aromatic hydrocarbons (PAHs) at temperatures between 300 and 500 °C in the presence of elemental sulfur, or during natural combustion process.⁵⁴

Table 1 Classification of natural nanoparticles in soils

Formation				Exemples
Natural	C-containing	Biogenic	Organic colloids	Humic, fulvic acids
		Geogenic	Soot	Fullerenes
		Atmospheric	Aerosols	Organic acids
		Pyrogenic	Soot	CNT Fullerenes
	Inorganic	Biogenic	Oxides	Magnetic
			Metals	Ag, Au
		geogenic	Oxides	Fe-oxides
			Clays	Allophane
		Atmospheric	Aerosols	Sea salt

Nanoparticles (NPs) behavior in soils

The processes affected by nanoparticles presence in soils (the role of the nano-size fraction) seems to gain importance in the last years, the sorption capacity, the interfacial electron transfer reactions, the mobility and the diffusive mass transfer playing an important role in soils properties. Sorption capacity of the NPs refers to some topics such as: assessment of sorption capacity of the NPs in soils; assessment of the NPs interactions with other minerals of the soil matrix and the resulting effects on contaminant and nutrient adsorption/desorption in soils; usage of NPs for groundwater cleanup and remediation purposes; evaluation and quantification of the controls or effects of different variables (physical, chemical, biological) on these processes.

Contaminant or nutrient sorption on NP surfaces has attracted the attention of researchers, several studies in soil chemistry showing that NPs have high sorption capacities for metal and anionic contaminants.^{55, 56, 57} It was found that the contaminant sequestration was accomplished mainly by surface complexation, but sorbed surface species can be encapsulated within interior surfaces of NP aggregates, a phenomenon with significant consequences for contaminant dispersion or remediation processes. Metallic species as Ni can be linked to natural short-ordered aluminosilicates⁵⁸, arsenate on TiO₂ surfaces⁵⁹, humic acids and aromatic compounds by multi walled carbon nanotubes MWCNTs.⁶⁰

Nanoparticles interactions with soil minerals and the effects on sorption and desorption of nutrients or contaminants was also studied. Research showed that Fe rich NPs competed efficiently with NOM for Pb binding in soils and water.⁶¹ Another aspect of the same phenomenon is related to the NPs competition with the aqueous species of contaminants and nutrients for available sorption sites on different sorbents present in soils.

Another aspect concerns how the aggregation affects surface energy and the available surface area for sorption and the timescales of adsorption or desorption of contaminants or nutrients from exposed surface and remote sorption sites within the aggregate structures. Research results have demonstrated that the relative reactivity of 5 and 32 nm particles as determined from Langmuir adsorption parameters did not present important variations despite differences in NP aggregation for these two different sizes. These results also suggested that the aggregation did not affect the extent of organic acid sorption, the challenge remaining the assessment the available surface area for NP sorption because of the aggregation.⁶² NPs have been used for groundwater cleaning up and contaminated sites remediation. CuO NPs were found as being an effective material for As(III) and As(V) adsorption.⁶³ Other possible applications investigated the potential of zero-valent FeNPs for treatment and remediation of persistent organic pollutants such as hexachlorocyclohexanes⁶⁴, phenantrene sorption by nano-TiO₂ and nano-ZnO particles for the adsorption of organic contaminants⁶⁵, the concentration depending effects of single-walled CNTs or MWCNTs in terrestrial ecosystems on decreasing HOC accumulation by earthworms.⁶⁶ Factors such as soil solution pH and ionic strength, elemental substitution in the NPs crystal structure may have an important impact on NP sorption extent and timescales. Chemically oxidized nanoporous sorbents with very good lead adsorption performance were used in batch adsorption experiments were conducted to study the effect of adsorbent dose, initial concentration and temperature on the removal of Pb(II) from aqueous systems, the adsorption being maximum for the initial pH in the range of 6.5-8.0.⁶⁷ The NPs mobility in soils would depend on the degree of the NP interactions with the mineral particles of the soil matrix. Recent studies demonstrated that NP may easily move through the soil profiles. For example, TiO₂ NPs transport behavior through saturated homogeneous soil columns showed that TiO₂ can remain suspended in soil suspension even after 10 days, the transport distances being about hundreds centimeters.⁶⁸ NPs such as CNTs can carry contaminants facilitating their transport through soil profiles via mass transfer.⁶⁹ Accelerated transport of Pb associated with Fe oxide NPs is observed in soil and river samples in Germany and Sweden⁷⁰, carbonaceous NPs enhancing the transport of hydrophobic organic contaminants HOCs in porous media. The movement of NPs in soils and through the soil profile is controlled by a number of geochemical variables: pH, ionic strength, content of NOM and clay in addition to NPs related properties: surface charge, size, charge, aggregation, surface coating and impurities. These facts clearly demonstrate the complexity associated with studies of this type with multiple variables and several effects. Soil pH is a major variable in controlling NP mobility. Research on CNTs showed the effects of acid treatment on: the surface properties, the colloidal stability, and the heavy metal sorption. The results showed that acid treatment increased the amount of acidic surface groups on the CNTs and controlled colloidal stability and their adsorption capacity. Other factors controlling NPs mobility are NP size, sorption kinetics and residence time.³⁴ MWCNTs were expected to gain widespread usage in commercial products, but concerns about environmental and human risks have been raised.⁷¹ Results from flow-through-column experiments in subsurface and drinking water systems demonstrated that pore water velocity influences MWCNTs transport with higher mobility at greater pore water velocities.

Separation and characterization of nanoparticles in soils

The thorough analysis of NPs (natural and engineered) involves the sequence of detection, identification, quantification and characterization. In a complex or heterogeneous sample, each step of this sequence is an individual challenge, field-flow-fractionation (FFF) being one of the most promising techniques to achieve relevant characterization. It becomes clear that new analytical methods are needed to quantify NPs in a wide variety of sample types. This task can be very difficult especially for impure and complex samples, like environmental, biological and food samples. Environmental samples (especially soils) are complex matrices, which may contain natural and engineered NPs besides other particles, varying in composition, size and shape. To solve the problem of detecting, identification, quantification and characterization of NPs a solution is to make use of an existing contrast between the NPs and the sample matrix or to create one. There are analytical tools available to obtain accurate results for simple matrices, but not too many for more complicated matrices. Detection by light-scattering (LS) techniques is based on the differences between the refractive index of the particles and of the medium.⁷² LS is not substance specific and for dynamic light scattering (DLS) the polydispersity of the NPs in the sample limits its applicability.⁷³ Mass spectrometry can not be used alone for NPs measurement if the composition of NPs is identical to the sample.⁷⁴ Electron microscopy (EM) makes use of spatial resolution and differences in composition and structure of the particles. It is good for identifying single particles, but it fails to provide a statistical representation of the whole sample.⁷⁵ Separation using ultra-filtration apparatus are based on gradient filtration using membranes with different molecular weight cutoffs (MWCs) for separating colloidal materials in soils into specific size-fractions.

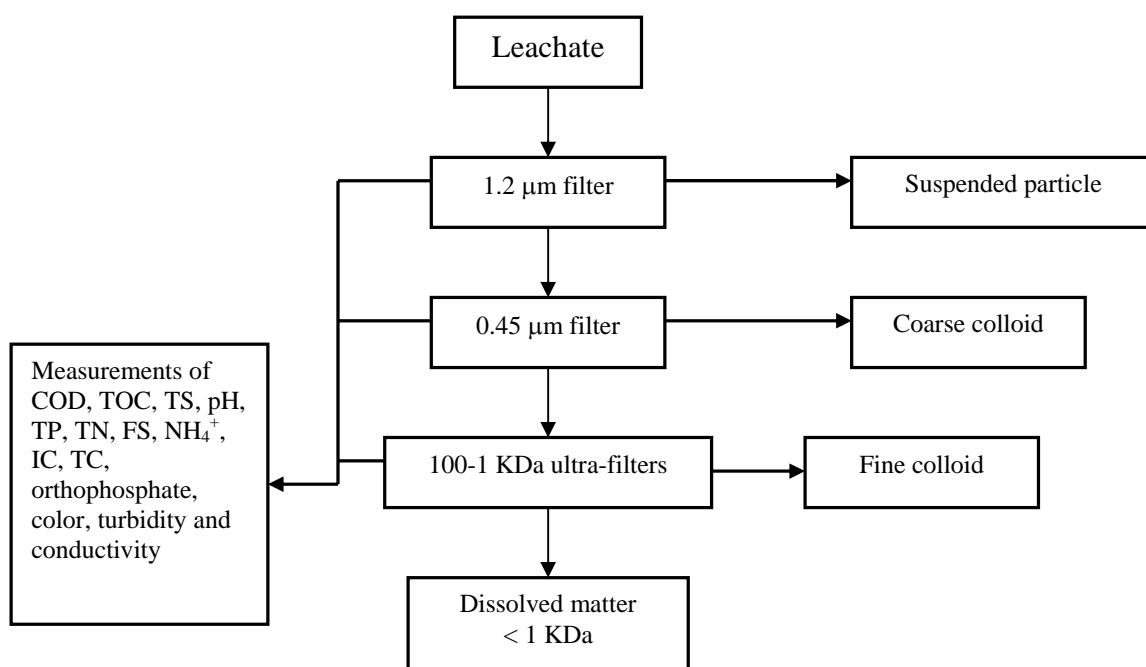

Fig. 1 Schematic separation of organic matter size fractionation using micro- and ultra-filtration

The soils are initially filters using 1.2 μm , followed by 0.45 μm membranes made of mixed cellulose, 0.22 μm and then on membranes with nominal MWCOs of 100, 30, 10 and 1 kDa (1 Da is equal to 1/16 of an O atomic mass unit). All membranes are made of polyether sulfone (PES).

The residue retained by the 1.2 μm membranes was defined as suspended solid, the residue retained by the 0.45 μm membranes as coarse colloids and the residue retained by the rest of the PES MWCO membranes as fine colloids. The materials remaining in solution after the 1 kDa MWCO membrane filtration step were defined as dissolved matter.

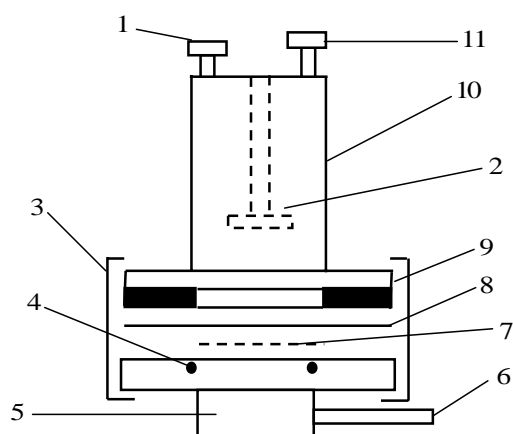

Fig. 2 Schema of an ultra-filter: 1. Admitting pipe; 2. Stirrer; 3. Fixator; 4. O-ring seal pack; 5. Seat; 6. Outlet; 7. Flow deflector; 8. Ultra membrane; 9. Scaling pipe; 10. Ultra filter cup; 11. Feed inlet

The combination with a hydrodynamic separation technique (e.g. field-flow fractionation FFF) offers the possibility of using all the potential of the aforementioned techniques. By separating macromolecules and particles, FFF reduces sample poly-dispersity and complexity for each of the analytical devices and ideally also adds particle-size information.⁷⁶

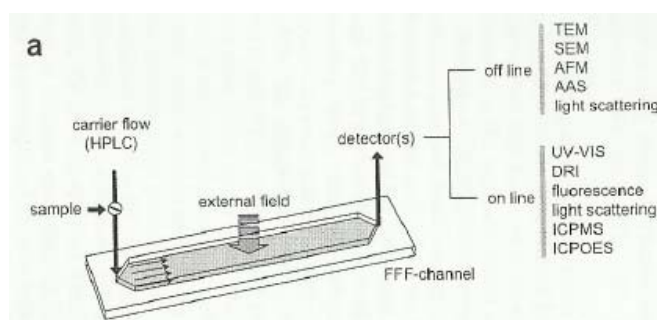

Fig. 3 Scheme of typical flow-field fractionation (reproduced with permission from F. van der Kammer et al., Trends in Anal. Chem. 2011, 30(3), 425-436)

Much of an FFF system resembles a classic liquid chromatography (LC) system (pumps, autosampler, detectors), FFF separates particles at low to medium pressure in an open channel without a stationary phase, the interactions of the NPs with the stationary phase being avoided. Since FFF is prone to interferences by large particles (> 1 μm), sample preparation is required for most samples, a suitable sample for FFF separation being a stable dispersion of NPs in a liquid medium, suitable sample-preparation technique playing a major role in FFF analysis.

Table 2 Example of application of FFF for characterization of nanoparticles in different matrices

Particle type	Size	Matrix	Separation	Detection	Ref.
Ni and U bound to humic acid	90-120 nm	Sediment extract	aF ⁴	UV-Vis 254 nm, ICP-MS	⁷⁷
Metal bound to humic acid	1-10 nm	Sediment extract	sF ⁴	UV-Vis 254 nm, ICP-MS	⁷⁸
Metal bound to humic substances	<10 nm	River sample	aF ⁴	MALLS, ICP-MS, TEM	⁷⁹
Macromolecules	<1000kDa	Compost leachates	aF ⁴	ICP-MS	⁸⁰
Polyethylene imine	25000 Da	Seawater	sF ⁴	UV-Vis 254 nm, ICP-MS, TEM	⁸¹
Humic acid	3790-3950 Da	Wastewater	sF ⁴	MALLS	⁸²
Complex of extracellular metal with polymeric substances	52-737 kDa	Synthesized suspension medium	aF ⁴	MALLS, TEM	⁸³

Sorption on carbon nanostructures in soils

Sorption is a surface phenomenon which may be either absorption or adsorption or a combination of the two. Adsorption is the association of an adsorbate compound onto a surface (sorber) usually in a liquid/solid or vapor/solid system, while absorption involves the redistribution of a compound from an aqueous phase into a volume of material. In geochemical systems, the two are indistinguishable and the term sorption is always used. Sorption is a fate mechanism that can be present in any aquatic or ground water system.

Sorption has been traditionally divided into two systems: weak physic-sorption and strong chemisorption. Each specific sorption interaction is usually somewhere in-between these two extremes. In order to understand these terms, we must understand first the molecular nature of the surface and of the sorbate.

Sorption is a term that includes several elementary reactions. Sorption can involve strong electrostatic interactions between ions or dipoles and surfaces, including ion exchange type reactions. Sorption can involve only weak intermolecular forces such as van der Waals interactions. As used by geochemists, sorption to natural surfaces also generally includes adsorption on surfaces and absorption into the material. The surface of a solid represents an interface between the gas or solution phase and the mineral

crystal. The nature of that interface depends on the nature of both the crystal phase and the solution or the gas phase. The solid surface can be represented as a surface of discrete sites and each one individually participates in a reaction resulting in sorption.

In general, nanoparticles can be used as sorbent materials in two configurations: chemically bonded, through a covalent bond to microparticles or directly used as raw materials. When these materials are used as sorbents, the interaction of the analyte can be produced directly on the nanoparticle surface or in the interstices of the aggregate. The non-covalent interaction established between the analyte and the nanoparticles or the nanostructured materials includes ionic interactions (dipole-dipole), hydrogen bonds, π - π stacking, dispersion forces, dative bonds and the hydrophobic effect. The presence of functionalized nanoparticles or supramolecular aggregates allows the possibility of incorporating one or more of these interactions.

In recent years, a large number of allotropic carbon nanoparticles have been described including: nanodiamonds⁸⁴, fullerene⁸⁵, nano-onions⁸⁶, carbon nanotubes (CNTs)⁸⁷, graphite nanosheets.⁸⁸ The sorptive capacity of conventional carbonaceous sorbents is limited by the density of the surface active sites, the activation energy of sorptive bonds, the slow kinetics and nonequilibrium of sorption in heterogeneous systems and the mass transfer rate to the sorbent surface. The large dimensions of traditional sorbents also limit their transport through low porosity environments and complicate the applications in subsurface remediation. Carbonaceous nanosorbents with their high surface area to volume ratio, controlled pore size distribution and surface chemistry overcome many of these intrinsic limitations. Sorption studies using carbon-based nanomaterials report rapid equilibrium rates, high adsorption capacity, being effective over a broad pH range and consistency with BET, Langmuir or Freundlich isotherms.⁸⁹ Direct sorption of organic contaminants to the nanomaterial surface is driven by the same fundamental hydrophobic, dispersion and weak dipolar forces to determine sorption energies in conventional systems.⁹⁰ The higher equilibrium rates of carbonaceous nanosorbents over activated carbon are attributed to⁹¹ π electron polarizability or π - π electron-donor acceptor interactions within aromatic sorbents, reduced heterogeneity of adsorption energies and the absence of pore diffusion as an intermediate mechanism in adsorption.⁹² This conclusion is reinforced by Yang et al.⁹³ comparing a variety of carbonaceous nanosorbents. Another advantage to carbonaceous nanosorbents is the virtual absence of hysteresis between adsorption and desorption isotherms for liquids and gases under atmospheric pressure. Enhanced atmospheric pressure relevant to gas adsorption in hydrogen storage applications may restore hysteresis in the system by reducing the energy barrier to fill nonwetting CNT pores and the intraparticle region of the nanoaggregates.⁹⁴ While rapid equilibrium rates and high sorbent capacity are powerful attributes of carbonaceous nanosorbents, their true revolutionary potential lies in the diverse pathways for tailored manipulations of their surface chemistry. Tailoring the dominant physical and chemical adsorption forces via selective functionalization yields carbonaceous nanomaterials that complement the existing suite of relatively unspecific conventional sorbents. Functionalized nanosorbents may provide an optimized approach for targeting micropollutants, removing contaminants.⁹⁵ CNTs functionalized with hydrophilic $-\text{OH}$ and $-\text{COOH}$ groups exhibited superior sorption of low molecular weight and polar compounds.⁹⁶ In contrast to the relatively nonspecific, hydrophobic sorption mechanisms describing organic sorption, inorganic sorption to carbonaceous nanostructures is characterized by specific complexation reactions. Surface functional group density rather than total surface area becomes the primary determinant of inorganic sorption capacity. Metal speciation or competing complexation reactions render sorption capacity sensitive to changes in pH.⁹⁷

Despite the synthesis costs, the cost effectiveness of carbon based nanomaterials vs. traditional activated carbon was demonstrated, the environmental applications of nanomaterials sorption capacity being not

limited to the removal or remediation of contaminants, but to controlled delivery of fertilizers and pesticides as well.

The adsorption isotherms

Adsorption isotherms describe the equilibrium relationship between bulk activity of adsorbate in solution and the moles adsorbed on the surface at constant temperature. Adsorption isotherm expressions are derived from fundamental principles of the adsorption process, experimental data fitting by isotherm expressions whether the experimental system satisfies the assumptions of the isotherm derivation or not. Brunauer described five general types of sorption isotherms:

1. **Langmuir type** offers a good representation of chemisorption and usually represents the low P portion of other isotherms. Adsorption sequentially fills surface sites until mono-layer coverage is achieved. No multi-layer coverage is included. Each site is equivalent in energy. Langmuir behavior assumes rapid reversible sorption and interaction only between sorbate molecules and a surface site. The lower portion is linear. The equation for the Langmuir isotherm is given by: $Q = Q_m b C_g / (1 + b C_g)$, where Q is the amount sorbed, Q_m is the monolayer coverage, C_g is the gas phase concentration and b is a constant. While the Langmuir isotherm is rarely useful in real heterogeneous systems, it illustrates well the concept of monolayer coverage.
2. **BET type**. The BET equation is an extension of the Langmuir relationship that accounts for multilayer coverage. Here, multiple layers can form before monolayer is complete with multiple layers forming as a condensation reaction. At high pressure, the adsorbate condenses to a bulk liquid on the surface, the number of layers becomes infinite. This isotherm describes well the physisorption of an organic onto dry surface soils. The equation $Q = Q_m c P / (P^0 - P) [1 + (c - 1)(P/P^0)]$, where P^0 is the saturated vapor pressure and c is a constant related to the energy (enthalpy) of adsorption. While this is effective in describing vapor-phase adsorption on dry soils, it does not describe electrostatic interactions of ions onto a heterogeneous surface in an aqueous system.
3. **Freundlich type**. A well-used empirical isotherm is the Freundlich relationship which allows, which allows for a heterogeneous surface that is more often seen in natural systems. When $1/n > 1$, the sorption constant increases with increasing solution concentration, perhaps reflecting an increase in the hydrophobic character of the surface after a monolayer. When $1/n < 1$, K decreases with solution concentration as the low-energy sites are occupied. $1/n$ slightly greater than 1 is often found for organic solutes. The Freundlich equation is: $Q = K_F C_s^{1/n}$

Linear isotherms. When $1/n=1$, the isotherm becomes a linear relationship which often closely describes the absorption reaction of an organic molecule partitioning into soil organic matter, having no linear portion. In this case, the distribution coefficient K_d describes a linear relationship between the dissolved concentration of adsorbate ion and the concentration adsorbed to the surface. Linear adsorption best describes systems at low concentrations where the Langmuir relationship is still linear. The end result assumes that the amount of a solute sorbed is proportional to the concentration in solution. The K_d expression is derived from the Langmuir isotherm, assuming a very small P and $KP \ll 1$. The measured K_d value is an operational parameter with no thermodynamic significance, but still useful in describing simple systems. The value of the K_d is restricted to the system for which the value was obtained.

Factors affecting sorption are the following ones: **surface area, mineral surface properties, organic carbon, solubility, temperature, pH, salinity, co-solvents** and **dissolved organic matter**.

Surface area. Adsorption is a surface phenomena directly related to surface area. Increasing the surface area the specific adsorption will increase. Sorption is usually reported as a bulk property on a per gram weight basis. Sorption should always be reported on an area basis, considering micropores and molecular porosity.

Mineral surfaces properties. Surface charge creates surface conditions in which there is an uneven charge distribution, creating a double-layer of ions, charged organic solutes exchanging with other counter-ions in the double layer, resulting in physisorption.

Organic carbon. It has been found that the sorption of hydrophobic organic compounds is strongly controlled by the presence of soil organic material. While the reaction resembles that a sorption and will fit a sorption isotherm, it is partitioning.

Solubility. As the solubility of a hydrophobic compound decreases, the adsorption coefficient increases from entropy driven interaction with the surface.

Temperature. Since adsorption is an exothermic process, K values usually decrease with increasing temperature. In general, a 10% decrease in K sorp would occur with a temperature rise from 20 to 30 °C.

pH. Only chemicals that tend to ionize are affected by the pH, on neutral molecules the only change will be in the character of the surface, at low pH humic materials being nearly neutral, for example and more hydrophobic. Changes in pH will affect organic acids and bases by changing solubility. Cations resulting from the protonation of an organic base may more strongly adsorb to soils than neutral species. Sorption of charged species will be affected by the pH.

Salinity. An increase in salinity can lower the adsorption coefficient of cations due to the replacement/exchange by alkali cations. The adsorption of acid herbicides increases with salinity at pH values above the pKa of the acid, pH influencing the affects of salinity. Neutral molecules are generally less affected by salinity but often show an increased adsorption with increasing salt concentration, probably due to the increase in the activity coefficient of neutral molecules and resulting decrease in aqueous solubility. Increasing salinity may also change the interlayer spacing of layer clays as well as the morphology of the soil organic matter.

Co-solvents. Co-solvents are water soluble organic solvents such as methanol or acetone and they can decrease the sorption constant K_{sorp} by increasing the apparent solubility. The pyrene K_{sorp} decreases by 30% in 10% methanol.

Natural nanoparticles in soils and environmental and agricultural applications as sorbents

Nanoparticles in soils can be divided into natural and anthropogenic particles, being further separated into carbon-containing and inorganic NPs. Natural and anthropogenic combustion processes that take place both in stationary and in mobile sources emit a variety of particles. From these particles the soot fraction of the black carbon correspond to the nano-sized BC. Soot as a product of re-condensation processes during incomplete combustion of fossil and renewable fuels is emitted into the atmosphere from where it is deposited onto soils and water bodies. Although fullerenes and CNT are considered as engineered NP, they are also natural particles (fullerenes) or CNTs. The majority is believed to have formed from polycyclic aromatic hydrocarbons (PAH) during metamorphosis at high temperatures and in the presence of elemental sulfur.⁹⁸

Dissolved organic carbon and organic colloids in the sub-micron size range have been recognized as distinct organic phase to which pollutants are partitioning. By their sheer abundance such sorbents may

attenuate the truly dissolved exposures of organic pollutants. Soot is an important adsorbent for organic compound, the nonlinear adsorption of organic compounds onto BC completely dominating total sorption at low aqueous concentrations in soils and sediments.⁹⁹ The efficient sorption to BC pulls toxic polycyclic aromatic hydrocarbons, polychlorinated biphenyls, dioxins, polybrominated diphenylethers and pesticides into sediments and soils¹⁰⁰, the presence of BC explaining that the sorption of organic compounds into soils and sediments is much higher in comparison with the absorption into the organic matter alone.

CNTs have proved to be adsorbents for organic compounds from water, examples including dioxin¹⁰¹, PAH¹⁰², DDT¹⁰³, chlorobenzenes and chlorophenols^{104, 105}, dyes¹⁰⁶, pesticides¹⁰⁷, herbicides^{108, 109}. In all cases, the available adsorption space was found to be the cylindrical external surface, neither the inner cavity, nor the the inter-wall space of multi-walled CNT.

Oxidized CNTs are also good adsorbents for metals such as: Cu¹¹⁰, Ni¹¹¹, Cd^{112, 113}, Pb¹¹⁴, Ag¹¹⁵ and rare earth metals.¹¹⁶ In all the cases, adsorption is pH dependent increasing sorption by increasing pH.

Fullerenes have also been tested for the adsorption of organic compounds, adsorption depending to a great extent on the dispersion state of the C60.¹¹⁷ incomplete dispersion leading to significant adsorption-desorption hysteresis.¹¹⁸ Ballesteros et al.,¹¹⁹ found that fullerenes are not very good sorbents for organic compounds, but they are efficient for the removal of organometallic contaminants.

There are some examples till the moment concerning sorption of several contaminants on natural carbon based nanomaterials in soils, these applications being listed in the table below.

Table 3 Natural carbon containing nanoparticles in soils as sorbents for contaminants

Formation	Type	Sorbent	Contaminant	Ref.
Biogenic	Organic colloids	Humic and fulvic acids	phenantrene	¹²⁰
Biogenic	Organic colloids	Humic and fulvic acids	atrazine	¹²¹
Biogenic	Organic colloids	Humic and fulvic acids	Th(IV)	¹²²
Geogenic	Soot	fullerenes	Organic contaminants	¹²³
Pyrogenic	Soot	CNTs	14C-phenantrene 14C-benzo[a]pyrene	¹²⁴
Pyrogenic	Soot	CNTs	arsenate	¹²⁵
Pyrogenic	Soot	CNTs	pesticides	¹²⁶
Pyrogenic	Soot	CNTs	pyrene	¹²⁷
Pyrogenic	Soot	CNTs	1,2-dichlorobenzene	¹²⁸
Pyrogenic	Soot	CNTs	Organic contaminants	¹²⁹
Pyrogenic	Soot	CNTs	243 Am(III)	¹³⁰

Engineered carbon nanomaterials (CNM) in soils as sorbents for environmental contaminants

The environmental applications of engineered carbonaceous nanomaterials are both proactive (preventing environmental degradation, improving public health, optimizing energy efficiency) and

retroactive (remediation, wastewater reuse, pollutant transformation). Carbon unique hybridization properties and the sensitivity of carbon's structure to perturbations in synthesis conditions allow for tailored manipulation to a degree not yet achieved by inorganic nanostructures¹³¹.

Wetting plays a key role in the nanotube capillarity. Hydrophobicity and capillarity also contribute to the adsorption behavior and orientation of sorbates in micro-porous carbons. Physisorption is the dominant mechanism of sorption for not functionalized nanomaterials. Adsorption studies report rapid equilibrium rates, high adsorption capacity, low sensitivity to pH range, minimal hysteresis in dispersed nanoparticle samples and consistency with traditional Langmuir, BET or Freundlich isotherms¹³².

Functionalized nanosorbents may provide an optimized approach for targeting specific micropollutants, removing low concentration contaminants or improving subsurface mobility. For instance, when compared to activated carbon, carbon nanotubes functionalized with hydrophilic $-OH$ and $-COOH$ groups exhibited superior sorption of low molecular weight and polar compounds. In contrast to the relatively non-specific, hydrophobic sorption mechanisms describing organic sorption, inorganic sorption to carbonaceous nanostructures is characterized by specific complexation reactions. Surface functional group density, rather than total surface area becomes the primary determinant of inorganic sorption capacity. Metal speciation or competing complexation reactions also render sorption capacity sensitive to changes in pH.

Although there are several examples in the literature illustrating the promising sorption properties of carbon based nanomaterials, their applications in real environmental samples and particularly in agriculture are very scarce. In this regards, this project will contribute to filling the existing gap between theory and experimental results by carrying out a comprehensive study of a wide range of novel nanosorbents with a truly multidisciplinary approach.

Nanotubes (CNTs) conceptually represent a micrometer-scale graphene sheet rolled into a cylinder nanoscale diameter and capped with spherical fullerenes. Extensive reviews have been published on the synthesis and structural conformation of CNTs, highlighting their position on the spectrum of carbon hybridization and the effect that this conformation has one property relevant to environmental applications.

The development of various methods for producing **graphene** - a single layer of carbon atoms bonded together in a hexagonal lattice and graphitic nanoplatelets - multilayer of carbon atoms bonded together in a hexagonal lattice has stimulated a vast amount of research in recent years. Graphene and chemically modified graphene (CMG) are promising candidates as components in applications, such as energy-storage materials, paper-like materials, polymer composites, environmental sorbent materials¹³³.

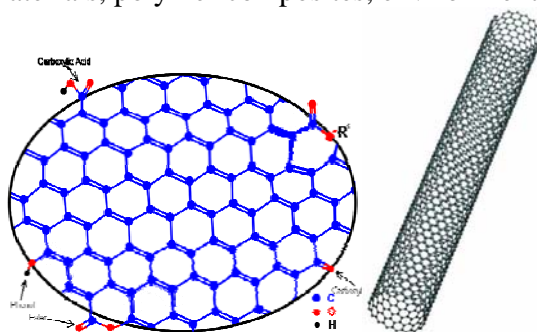

Fig. 4. Schema of carbon based nanomaterials: functionalized graphene and CNT

Functionalized CNTs, graphitic nanoplatelets and graphene can be used to bind contaminants such as heavy metals, organochlorine remanent pesticides, organophosphate pesticides and polychlorinated

biphenyls (PCBs). The amount of the contaminant that binds to the nanotube is up to ten times higher than the weight of the CNM. Both CNTs and graphene will be embedded in liquid permeable materials. Direct sorption of organic contaminants at the nanomaterial surface is driven by the same fundamental hydrophobic dispersion and weak dipolar forces that determine sorption energies in conventional systems. The higher equilibrium rates of carbonaceous nanosorbents over activated carbon are attributed to π - π electron-donor acceptor. Interactions with aromatic sorbates reduced heterogeneity of adsorption energies and the absence of pore diffusion as an intermediate mechanism in adsorption¹³⁴. This conclusion is reinforced by results comparing a variety of carbon nanosorbents. Another advantage to carbon nanosorbents is the virtual absence of hysteresis between adsorption and desorption isotherms for liquid and gases under atmospheric pressure.

Table 4 Engineered based carbon nanoparticles CNTs as sorbents for contaminants (inorganic and organic ones)

Sorbent	Application	Contaminant	Ref
Iminodiacetic acid functionalized MWCNTs	Separation and preconcentration	Heavy metals	135
CNTs and carbon encapsulated magnetic nanoparticles	Kinetics of sorption	Copper ions	136
CNTs doped with metal impurities	Sorption from aqueous solutions	Pb(II)	137
Modified MWCNTs	Sorbents	Traces of gold (III)	138
CNTs and carbon encapsulated magnetic nanoparticles	Sorbents	Heavy metals	139
Carbon-nanotube silver composite	Sorbent for capture and analysis	Hg(II)	140
Ag-CNTs	Mercury trap	Hg(II)	141
Oxidized MWCNTs	Sorption from aqueous solutions	Pb(II)	142
L-cysteine functionalized MWCNTs	Selective sorption and preconcentration	Heavy metals	143
Non-oxidized MWCNTs	Enrichment efficiency of sorption	Metal ions	144
CNTs	Sorption from aqueous solutions	Divalent metal ions	145
Carbon nanosorbents	Concentration and separation	Metal ions	146
Carbon nanotubes	Sorbent for aqueous solutions	Ni(II)	147
Modified CNTs	adsorption	sulfamethoxazole	148
MWCNTs	Competitive adsorption	Naphthalene, 2,4-dichlorophenol, 4-chloroaniline	149
Natural organic matter	Sorption in natural samples	Organic contaminants	150

(NOM) CNTs	in the presence of NOM		
CNTs	Adsorption	phenolic compounds	151
CNTs	Sorption in the presence of NOM	Organic contaminants	152
MWCNTs	Competitive sorption	Pyrene, phenantrene, naphthalene	153

Table 5 Engineered based carbon nanoparticles (graphene) as sorbents for contaminants (inorganic and organic ones)

Sorbent	Application	Contaminant	Ref
Lignite activated nanostructured carbon	Fixed-bed results	HgCl ₂	154
Oxidized MWCNTs and graphene	Mixed sorbents	Zn(II) and naphthalene	155
Nanostructured wood charcoal	Natural sorption	Hydrophobic organic compounds	156
Surface modified graphite nanosheets	Adsorbent for water samples	1,2-dichlorobenzene	157
Graphite and soot	Mediated reduction	2,4-dinitrotoluene, hexahydro-1,3,5-trinitro-1,3,5-triazine	158
Nanoporous carbon xerogels	sorbent	Organic contaminants	159
Wood charcoals	Different thermochemical conditions	Single-ring organic compounds	160
Nanostructured black carbon	sorbent	Aromatic compounds	161
Nanostructured charcoal	Competitive experiments	Aromatic compounds	162
Exfoliated graphite nanoplatelets (xGnP)	Sorption from aqueous solutions	Phenolic compounds	163
Exfoliated oxidized graphite nanoplatelets (xGnP)	Sorption from aqueous solutions	Pb(II)	164
Nanostructured wood charcoal	sorbents	Hydrophobic contaminants	165



Fig. 5 Possible solution for water decontamination using nanomaterials impregnated curtains

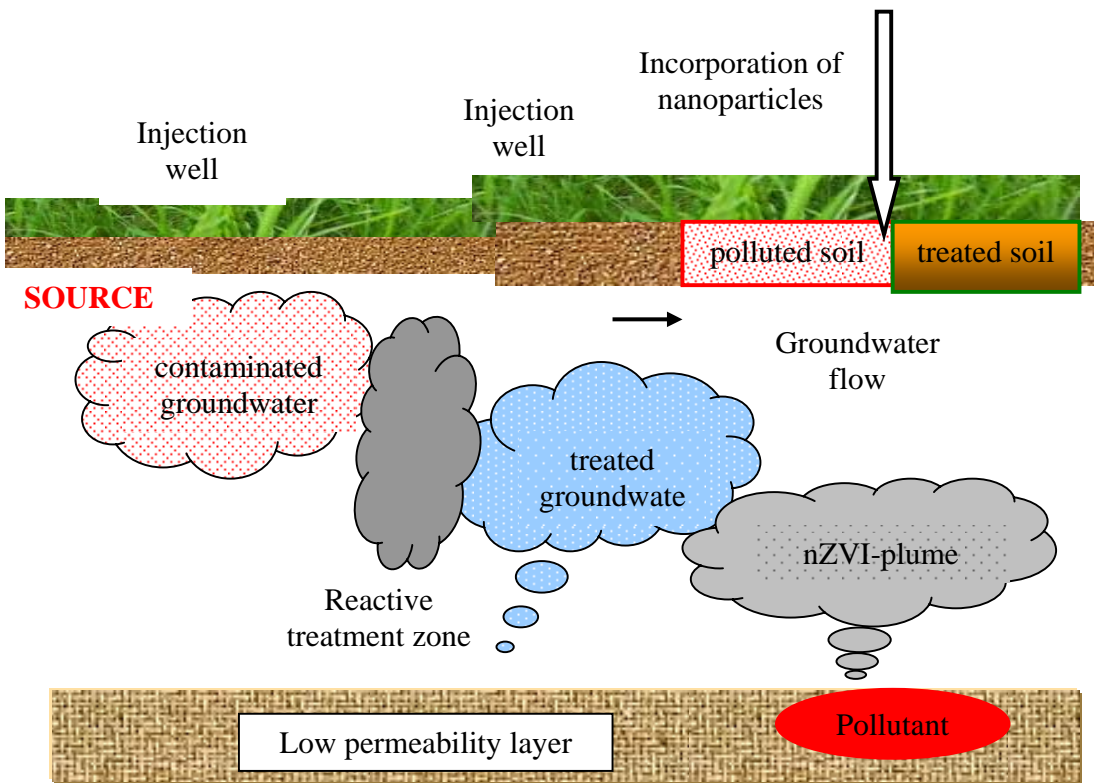

Fig. 6 Solution for soil decontamination using nanoparticles

The decontamination processes will take place simultaneously by entrapping the proposed nanomaterials (mixing as grown and oxidized CNTs or graphene) in combination on different supports and introducing these tools in the flow path of contaminated waters. Their performance will be assessed by testing samples from contaminated areas before and after decontamination using the developed filtration methods and tools.

Conclusion

Nanotechnologies can find applications in many others environmental and agri-food thematic areas:

- in **efficient use of soil resources** (nanoparticles in soil in situ remediation, absorption and release of contaminants in soils; nanoscale iron particles in rapid destruction of chlorinated hydrocarbons in soil and groundwater; nanosensors in monitoring of heavy metals)
- in **efficient use of water resources** (nanotechnology in desalination and water purification; nanoporous membranes in filtration of viruses; nano-sponges in the absorption of toxic metals)
- in **delivery mechanism in plant, soil and animal systems** (mesoporous silica nanoparticles in delivering DNA and chemicals into plants; smart magnetic silica core-shell nanomaterials in specific targeting, cell sorting and bio-imaging; organically modified silica nanoparticles as DNA carriers; carbon nanofibers in gene therapy of plants; carbon nanotubes as molecular transporters)
- in **the use of agricultural waste/biomass** (biosynthesis of nanoparticles by microbes, biosynthesis of nanoparticles by the utilization of agriculture residues)
- in **food processing** (nanotechnology in food safety and quality control and in the production of functional and nutritive food; in biosensors, nanocantilevers, carbon nanotubes)
- in **food packaging** (nanoscale titanium dioxide particles in plastic packaging, nanosensors, bio-polymers based nanocomposites for safe storage)

This review treated in the its first part the applications of natural and engineered carbon-based nanomaterials as sorbents for environmental contaminants, a second part offering a synthesis of carbon-based nanomaterials with applications in sensors for pesticides.

References

-
- ¹ M.C. Roco, J. Nanopart. Res. 5(3-4) (2003) 181-189
 - ² USDA Nanoscale Science and Engineering for Agriculture and Food Systems, Dept. of Agriculture, United States 2003
 - ³ S. M. Ponder, J. G. Darbab, T. E. Mallouk, Environ. Sci. Technol. 34 (2000), 2564
 - ⁴ X. Li, W. Zhang, Langmuir 22 (2006) 4638
 - ⁵ J.S. Hu, L.S. Zhong, W.G. Song, L.J. Wan, Adv. Mater. 20 (2008) 2977
 - ⁶ O.M. Kalfa, O. Yalcikaya, A.R. Turker, J. Hazard. Mater. 166 (2009) 455
 - ⁷ X. Tan, C. Chen, S. Yu, X. Wang, Appl. Geochem. 23 (2008), 2767
 - ⁸ S. R. Kanel, B. Manning, L. Charlet, H. Choi, Environ. Sci. Technol. 39 (2005), 1291
 - ⁹ H. Song, E.R. Carraway, Appl. Catal. B: Environ. 78 (2008), 53
 - ¹⁰ T. Phenrat, N. Saleh, K. Sirk, R.D. Tilton, G.W. Lowry, Environ. Sci. Technol. 41 (2007), 284
 - ¹¹ C. Li, Y. Chen, K. Chiu, H.K. Yak, Surf. Sci 600 (2006), 1382
 - ¹² Y.S. Keum, Q. X. Li, Environ. Sci. Technol. 39 (2005), 2280
 - ¹³ H.Y. Kim, I.K. Kim, J.H. Shim, Y.C. Kim, T.H. Han, K. C. Chung, P.I. Kim, B. T. Oh, I.S. Kim, Bull. Environ. Contam. Toxicol. 77 (2006), 826
 - ¹⁴ D.S. Alessi, Z. Li, Environ. Sci. Technol. 35 (2001), 3713
 - ¹⁵ C.B. Wang, W.X. Zhang, Environ. Sci. Technol. 31 (1997), 2154
 - ¹⁶ J.H. Kim, P.G. Tratnyek, Y.S. Chang, Environ. Sci. Technol. 42 (2008), 4106
 - ¹⁷ K.C.K. Lai, I.M. C. Lo, Environ. Sci. Technol. 42 (2008), 1238
 - ¹⁸ B. W. S. Choi et al., Adv. Funct. Mater. 20 (2010), 820-825
 - ¹⁹ A.B. Prevot, D. Fabbri, E. Pramauro, A. M. Rubio, M. De la Guardia, Chemosphere 44 (2001), 249-255

-
- ²⁰ R. Ullah, J. Dutta, *J. Hazard Mater.* 156 (2008), 194
- ²¹ S. Baruah, J. Dutta, *Sci. Technol. Adv. Mater.* 10(013001):18 (2009)
- ²² M. A. Rahman, M. Muneer, *Desalination* 181 (2005) 161-172
- ²³ G. Zhanqi, Y. Shaogui, T. Na, S. Cheng, *J. Hazard. Mater.* 145 (2007), 424-430
- ²⁴ B. Yu, J. Zeng, L. Gong, M. Zhang, L. Zhang, X. Chen, *Talanta* 72 (2002), 1667-1674
- ²⁵ O. Jost, A. Gorbunov, X. J. Liu, W. Pompe, J. Fink, *J. Nanosci. Nanotechnol.* 4 (2004), 433-440
- ²⁶ H. Andreas, *Angew. Chem. Int. Ed.* 2002, 41, 1853-1859
- ²⁷ J. Holt, H. Park, Y. Wang, M. Stadermann, A. Artyukhin, C. Grigoropoulos, A. Noy, O. Bakajin, *Science* 312 (2006), 312, 1034-1037
- ²⁸ C.H. Jin, K. Suenaga, S. Iijima, *Nat. Nanotechnol.* 3 (2008), 17-21
- ²⁹ R.J. Hunter, *Foundation of the Colloidal Science*, 2nd ed., Oxford University Press: Oxford; New York, 2001
- ³⁰ V.L. Colvin, *Clean water from small materials in Nanotechnology of the environment* MRS: Boston MA, 2007
- ³¹ Y. Saito, S. Uemura, *Carbon* 38 (2000), 169-182
- ³² *Carbon Nanotubes: Synthesis, structure, properties and applications*, Dresselhaus M.S. Ed.; Springer: Berlin, NY, 2001; vol 80
- ³³ Y. Hu, O. Shenderova, D. Brenner, *J. Comput. Theor. Nanosci.* 4 (2007), 199-221
- ³⁴ R.J. Hunter "Foundation of Colloid Science" nd Ed; Oxford University Press: Oxford; New York, 2001
- ³⁵ J. Hilding, E.A. Grulke, S.B. Sinnott, D. Qian, R. Andrews, m. Jagtoyen, *Langmuir* 17 (2001), 7540-7544
- ³⁶ W. Chen, L. Duan, D. Zhu, D.Q. Zhu, *Environ. Sci. Technol.* 41 (2007), 8295-8300
- ³⁷ M.F.Hochella,, *Geochim. Cosmochim. Acta*, 71 (2007), A 408.
- ³⁸ P.A.Maurice, M.F.Hochella, *Adv.Agron.* 100 (2008),123-153.
- ³⁹ B.K.G.Theng and G.D. Yuan, *Elements*, 4 (2008), 395-309.
- ⁴⁰ G.A. Waychunas, C.S.Kim, J.F.Banfield, *J.Nanopart. Res.* 7 (2005), 409-433.
- ⁴¹ F.Adani, S.Salati, M.Spagnol, F.Tambone, P.Genevini, R.Pilu, *Chromosphere* 76 (2009), 76,523-528.
- ⁴² M.F.Hochella, S.K.Lower, P.A.Maurice, R.L. Penn, N.Sahai, D.L..Sparks, B.S.Twining, *.Science* 319 (2008), 1631-1635.
- ⁴³ N.P.Quafoku,, „Impact of Environmental Nanoparticles on Physical, Chemical, Biological and Hydrological Processes in Terrestrial ecosystems Handbook of Soil Science”, 2010.
- ⁴⁴ N.P.Qafoku, C.C. Ainsworth, J.E.Szecsody , O.S.Qafoku, *J. Environ. Qual.* 32 (2003), 2354–2363.
- ⁴⁵ N.P.Qafoku, C.C.Ainsworth, J.E.Szecsod, D.L. Bish, J.S.Young, D.E.McCready and O.S.Qafoku,, *J. Environ. Qual.* 32 (2003), 2364–2372.
- ⁴⁶ N.P. Qafoku, O.S. Qafoku, C.C. Ainsworth, A. Dohnalkova and S.G.McKinley, *Appl. Geochem.* 22 (2007), 2054–2064.
- ⁴⁷ D.M.Singer, F.Farges and G.E.Jr. Brown, *Geochim. Cosmochim. Acta* 73 (2009), 3593–3611.
- ⁴⁸ J. Miot, K. Benzerara, G. Morin, A. Kappler, S. Bernard, M. Obst, C. Ferard, F. Skouri-Panet, J.M. Guigner, N. Posth, M. Galvez, G.E. Brown and F.Guyot, *Geochim. Cosmochim. Acta* 73 (2009), 696–711.
- ⁴⁹ D. Carta, M.F. Casula, A. Corrias, A. Falqui, G. Navarra, G. and Pinna, *Mater. Chem. Phys.* 113 (2009), 349–355.
- ⁵⁰ B. Nowack , T. D. Bucheli, *Environ. Pollut.* 150 (2007), 150, 5–22.
- ⁵¹ L. Becker, R.J. Poreda, A.G. Hunt, T.E. Bunch, M. Rampino, *Science* 291 (2001), 1530-1533
- ⁵² J. Buffle, *Environ. Chem.* 2006, 3, 155-158
- ⁵³ E.D. Goldberg, "Black carbon in the environment", 1985 John Wiley&Sons, NewYork
- ⁵⁴ D. Heymann, L.W. Jenneskens, J. Jehlicka, C. Koper, E. Vlietstra, 2003, *Fuller. Nanotub. Carbon Nanostruct.* 11 (2003), 11, 333-370
- ⁵⁵ G.A. Waychunas, C.S. Kim, J.F. Banfield, *J. Nanopart. Res.* 7 (2005), 409-433
- ⁵⁶ R.F. Domingos, N. Tufenkji, K.J. Wilkinson, *Environ. Sci. Technol.* 43 (2009), 1282-1286
- ⁵⁷ C.B. Mendive, T. Bredow, A. Feldhoff, M. A. Blesa, D. Bahnemann, *Phys. Chem. Phys.* 11 (2009), 1794-1808
- ⁵⁸ C. Levard, E. Doelsch, J. Rose, A. Masion, I. Basile-Doelsch, O. Proux, J.-L. Hazeman, D. Borschneck, J.-Y. Bottero, *Geochim. Cosmochim.* 73 (2009), 4750-4760
- ⁵⁹ H. J. Zhang, G.H. Chen, *Environ. Sci. Technol.* 43 (2009), 2905-2910
- ⁶⁰ X. Wang, S. Tao, B. Xing, *Environ. Sci. Technol.* 43 (2009), 6214-6219
- ⁶¹ M. Hasselov, F. von der Kammer, *Elements*, 4 (2008), 401-406
- ⁶² J.M. Pettibone, D.M. Cwiertny, D.M. Scherer, V.H. Grassia, *Langmuir*, 24 (2008), 6659-6667
- ⁶³ C.A. Martinson, K.J. Reddy, *J. Colloid Interface Sci.* 336 (2009), 406-411
- ⁶⁴ D.W. Elliot, H.L. Lien, W.X. Zhang, *J. Environ. Qual.* 37 (2009), 2192-2201
- ⁶⁵ K. Yang, B.S. Xin, *Environ. Sci. Technol.* 43 (2009), 1845-1851

-
- ⁶⁶ E.J. Petersen, R.A. Pinto, P.F. Landrum, J. Weber, J. Walter, *Environ. Sci. Technol.* 43 (2009), 4181-4187
- ⁶⁷ M.J. Baniamerian, s.E. Moradi, A. Noori, H. Salahi, *Appl. Surf. Sci.* 256 (2009), 1347-1354
- ⁶⁸ J. Fang, X.-Q. Shan, B. Wen, J.-M. Lin, G. Owens, *Environ. Pollut.* 157 (2009), 1101-1109
- ⁶⁹ A. Schierz, H. Zanker, *Environ. Pollut.* 157 (2009), 1088-1094
- ⁷⁰ T. Hofmann, F. von der Kammer, *Environ. Pollut.* 209 (2009), 1117-1126
- ⁷¹ X. Liu, D.M. O'Carroll, E.J. Petersen, Q. Huang, C.L. Anderson, *Environ. Sci. Technol.* 43 (2009), 8153-8158
- ⁷² A. Cao, *Anal. Lett.* 36 (2003), 3185
- ⁷³ K. Tiede, M. Hasselov, E. Breitbarth, Q. Chaudry, A.B. A. Boxall, *J. Chromatogr. A*, 2009, 503
- ⁷⁴ K. Plathe, F. von der Kammer, M. Hasselov, J. Moore, M. Murayama, T. Hofmann, M. F. Hochella, *Environ. Chem.* 7 (2010), 82
- ⁷⁵ K. Tiede, A.B.A. Boxall, S.P. Tear, J. Lewis, H. David, M. Hasselov, *Food Addit. Contam.* (2008), 795
- ⁷⁶ J.C. Giddins, "The field-flow fractionation family: underlying principles" in *Field-flow fractionation handbook*, Wiley, New York USA, 2000, pp. 3-29
- ⁷⁷ B.P. Jackson, J.F. Ranville, P.M. Bertsch, A.G. Sowder, *Environ. Sci. Technol.* 39 (2005), 2478.
- ⁷⁸ A. Siripinyanond, R.M. Barnes, D. Amarasiriwardena, *J. Anal. Atom. Spectrom.* 17 (2002), 1055.
- ⁷⁹ M. Baalousha, F.V.D. Kammer, M. Motelica-Heino, M. Baborowski, C. Hofmeister, P. Le Coustumer, *J. Chromatogr. A*, 109 (2005), 3156.
- ⁸⁰ E. Bolea, F. Laborda, J.R. Castillo, *Anal. Chim. Acta* 661 (2010), 206.
- ⁸¹ S. Dubascoux, F. Von Der Kammer, I. Le Hécho, M.P. Gautier, G. Lespes, *J. Chromatogr. A* 1206 (2008), 160.
- ⁸² D. Amarasiriwardena, A. Siripinyanond, R.M. Barnes, *J. Anal. Atom. Spectrom.* 16 (2001), 978.
- ⁸³ E. Alasonati, S. Dubascoux, G. Lespes, V.I. Slaveykova, *Environ. Chem.* 7 (2010), 215.
- ⁸⁴ J. Y. Raty, G. Galli, *J. Electroanal. Chem.* 9 (2005), 584
- ⁸⁵ G. Jiang, Q. Zheng, *J. Appl. Polymer Sci.* 97 (2005), 2182
- ⁸⁶ D. Roy, M. Chhowalla, H. Wang, N. Sano, I. Alexandrou, T.W. Claine, G.A. J. Amaratunga, *Chem. Phys. Lett.* 373 (2003), 52
- ⁸⁷ H. Dai, *Surf. Sci.* 500 (2002), 218
- ⁸⁸ X. Li, G. Chen, *Mat. Lett.* 63 (2009), 930-932
- ⁸⁹ K. Yang, X.L. Wang, L.Z. Zhu, B.S. Xing, *Environ. Sci. Technol.* 40 (2006), 1855-1861
- ⁹⁰ R.M. Allen-King, P. Grathwoll, W.P. Ball, *Adv. Water Resour.* 25 (2002), 985-1016
- ⁹¹ S. Gotovac, Y. Hattori, D. Noguchi, J. Miyamoto, M. Kanamaru, S. Utsumi, H. Kanoh, K. Kaneko, *J. Phys. Chem. B* 110 (2006), 6236-6244
- ⁹² X. J. Peng, Y.H. Li, Z.K. Luan, Z.C. Di, H.Y. Wang, B.H. Tian, Z.P. Jia, *Chem. Phys. Lett.* 376 (2003), 154-158
- ⁹³ F.H. Yang, A.J. Lachawiek, R.T. Yang, *J. Phys. Chem. B* 110 (2006), 6236-6244
- ⁹⁴ V. K. Punyamurtula, Y. Qiao, *Mater. Res. Innovation* 11 (2007), 37-39
- ⁹⁵ H. Yan, A.J. Gong, H.S. He, J. Zhou, Y. X. Wei, I. Lv, *Chemosphere* 62 (2006), 142-148
- ⁹⁶ C.S. Lu, Y.L. Chung, C.F. Chang, *Water Res.* 39 (2005), 1183-1189
- ⁹⁷ X. K. Wang, C.L. Chen, W.P. Hu, A.P. Ding, D. Xu, X. Zhou, *Environ. Sci. Technol.* 39 (2005), 2856-2860
- ⁹⁸ D. Heymann, L.W. Jenneskens, J. Jehlicka, C. Koper, E. Vlietstra, *Fuller. Nanotub. Carbon Nanostruct.* 11 (2003), 333-370
- ⁹⁹ G. Cornelissen, O. Gustafsson, T.D. Bucheli, M.T.O. Jonker, A.A. Koelmans, P.C.M. van Noort, *Environ. Sci. Technol.* 39 (2005), 6881-6885
- ¹⁰⁰ A.A. Koelmans, M.T.O. Jonker, G. Cornelissen, T.D. Bucheli, P.C.M. Van Noort, O. Gustafsson, *Chemosphere* 63 (2006), 365-377
- ¹⁰¹ R.Q. Long, R.T. Yang, *J. Am. Chem. Soc.* 123 (2001), 2058-2059
- ¹⁰² S. Gotovac, Y. Hattori, D. Noguchi, J. Miyamoto, M. Kanamaru, S. Utsumi, H. Kanoh, K. Kaneko, *J. Phys. Chem. B* 110 (2006), 16219-16224.
- ¹⁰³ Q.X. Zhou, J.P. Xiao, W.D. Wang, *J. Chromatogr. A* 1125 (2006), 152-158.
- ¹⁰⁴ X.J. Peng, Y.H. Li, Z.K. Luan, Z.C. Di, H.Y. Wang, B.H. Tian, Z.P. Jia, *Chem. Phys. Lett.* 376 (2003), 154-158.
- ¹⁰⁵ Y.Q. Cai, Y.E. Cai, S.F. Mou, Y.Q. Lu, *J. Chromatogr. A*. 1081 (2005), 245-247.
- ¹⁰⁶ B. Fugetsu, S. Satoh, T. Shiba, T. Mizutani, B. Lin, N. Terui, Y. Nodasaka, K. Sasa, K. Shimizu, T. Akasaka, M. Shindoh, K. I. Shibata, A. Yokoyama, M. Mori, K. Tanaka, Y. Sato, K. Tohji, S. Tanaka, N. Nishi, F. Watari, *Environ. Sci. Technol.* 38 (2004), 6890-6896.
- ¹⁰⁷ Q.X. Zhou, X.J. Ding, J.P. Xiao, *Anal. Bioanal. Chem.* 385 (2006), 1520-1525.

- ¹⁰⁸ Q.X.Zhou, J.P.Xiao, W.D.wang, *Microchim.Acta* 157 (2007), 93-98.
- ¹⁰⁹ M.Biesaga, K.Pyrzynska, *J.Sep.Sci.* 29 (2006), 2241-2244.
- ¹¹⁰ P.Liang Q.Ding, F.Song, *J.Sep.Sci.* 28 (2005), 2339-2343.
- ¹¹¹ C.L.Chen, X.K.Wang, *Ind.Eng.Chem. Res.* 45 (2006), 9144-9149.
- ¹¹² Y.H.Li, S.G. Wang, Z.K.Luan, J.Ding, C.L.Xu, D.H.Wu, *Carbon* 41 (2003), 1057-1062.
- ¹¹³ P.Liang, Y.Liu, L.Guo, J.Zeng, H.B.Lu, *J.Anal.At.Spectrom.* 19 (2004), 1489-1492.
- ¹¹⁴ Y.H.Li, Y.Q.Zhu, Y.M.Zhao, D.H.Wu, Z.K.Luan, *Diam.Relat.Mater.* 15 (2006), 90-94.
- ¹¹⁵ Q.Ding, P.Liang, F.Song, A.Xiang, *Sep.Sci.Technol.* 41 (2006), 2723-2732.
- ¹¹⁶ P.Liang, Y.Yu, L.Guo, *Spectrochim.Acta B* 60 (2005), 125-129.
- ¹¹⁷ X.Cheng, A.T.Kan, M.B.Tomson, *J.Nanopart.Res.* 7 (2005), 555-567.
- ¹¹⁸ K.Yang, B.Xing, *Environ. Pollut.* 145 (2007), 529-537.
- ¹¹⁹ E.Ballesteros, M.Gallego, M.Varcarcel, *J.Chromatogr.A* 869 (2000), 101-110.
- ¹²⁰ K. Yang, L. Zhu, B. Xing, *Environ. Sci. Pollut. Research* 17(2) (2010), 410-419
- ¹²¹ J. Lu, Y. Li, X. Yan, B. Shi, D. Wang, H. Tang, *Colloids and Surfaces A: Physicochemical and Engineering Aspects*, 347(1-3) (2009), 90-96
- ¹²² X. Tan, X. Wang, C. Chen, A. Sun, *Applied Radiation and Isotopes* 65(4) (2007), 375-381
- ¹²³ D. Li, D.Y. Lyon, Q. Li, P.J.J. Alvarez, *Environ. Toxicol. And Chemistry* 27(9) (2008), 1888-1894
- ¹²⁴ M.G. Towell, L.A. Browne, G.I. Paton, K.T. Semple, *Environ. Pollut.* 159 (2011), 706-715
- ¹²⁵ C. Yuan, C.-H. Hung, K.-C. Chen, *J. Haz. Mat.* (1-3) (2009), 563-570
- ¹²⁶ M. Assensio-Ramos, J. Borges-Hernandez, T.M. Borges-Miguel, M.A. Rodriguez-Delgado, *Anal. Chim. Acta* 647(2) (2009), 167-176
- ¹²⁷ E. J. Petersen, R.A. Pinto, P.F. Landrum, W.J. Weler Jr., *Environ. Sci. Technol.* 43(11) (2009), 4181-4187
- ¹²⁸ C. Yuan, C.-H. Hung, W.-L. Huang, *Separation Sci. Technol.* 44(10) (2009), 2284-2303
- ¹²⁹ X. Wang, L. U. Jialong, B. Xing, *Environ. Sci. Technol.* 42(9) (2008), 3207-3212
- ¹³⁰ X. Wang, C. Chen, W. Hu, A. Ding, D. Xu, X. Zhou, *Environ. Sci. Technol.* 39(8) (2005), 2856-2860
- ¹³¹ B. Nowack, T.D. Bucheli, *Environ. Pollut.* 150(1) (2007), 5-22
- ¹³² W. Chen, L. Duan, D.Q. Zhu, *Environ. Sci. Technol.* 41 (2007), 8295-8300
- ¹³³ S. Park, R. S. Ruoff, *Nature nanotechnology* 58 (2009), 217-224
- ¹³⁴ S. Gotovac, Y. Hattori, D. Noguchi, J. Miyamoto, M. Kanamaru, S. Utsumi, H. Kanoh, K. Kaneko, *J. Phys. Chem. B* 110 (2006), 16219-16224
- ¹³⁵ J. Wang, X. Max, G. Fang, M. Pan, X. Ye, S. Wang, *J. Haz. Mat.* 186(2-3) (2011), 1985-1992
- ¹³⁶ M. Bystrzejewski, K. Pyrzynska, *Colloids and Surfaces A: Physicochemical and Engineering Aspects*, 2011 in press
- ¹³⁷ X. Tian, S. Zhou, Z. Zhang, X. He, M. Yu, D. Lin, *Environ. Sci. Technol.* 44 (2010), 8144-8149
- ¹³⁸ D. Afzali, S. Ghaseminezhad, M.A. Taher, *J. AOAC International* 93(4) (2010), 1287-1292
- ¹³⁹ K. Pyrzynska, M. Bystrzejewski, *Colloids and Surfaces: Physicochemical and Engineering Aspects* 362(1-3) (2010), 102-109
- ¹⁴⁰ G. Luo, H. Yao, M. Xu, X. Ciu, W. Chen, R. Gupta, Z. Xu, *Energy and Fuels* 24(1) (2010), 419-426
- ¹⁴¹ G. Luo, H. Yao, M. Xu, Z. Xu, *J. Huazhong Univ. of Science and Technology* 38(1) (2010), 129-132
- ¹⁴² D. Xu, X. Tan, C. Chen, X. Wang, *J. Haz. Mat.* 154(1-3) (2008), 407-416
- ¹⁴³ Y. Liu, Y. Li, X.-P. Yan, *Advanced Functional Materials* 18(10) (2008), 1536-1543
- ¹⁴⁴ A.H. El-Sheikh, *Talanta* 7591) (2008), 127-134
- ¹⁴⁵ G.P. Rao, C. Lu, F. Su, *Separation and Purification Technology* 58(1) (2007), 224-231
- ¹⁴⁶ K. Pyrzynska, *Anal. Sci.* 23(6) (2007), 631-637
- ¹⁴⁷ C. Lu, C. Liu, *J. Chem. Technol.* 81(12) (2006), 1932-1940
- ¹⁴⁸ X. Zhang, B. Pan, K. Yang, D. Zhang, J. Ho, *J. Environ. Sci. And Health(A)/Toxic hazardous substances&environmental engineering* 45(12) (2010), 1625-1634
- ¹⁴⁹ K. Yang, W. Wu, O. Jing, W. Jiang, B. Xing,, *Environ. Sci. Technol.* 44(8) (2010), 3021-3027
- ¹⁵⁰ X. Wang, B. Xing, *ACS National Meeting Book of Abstracts*, 2008
- ¹⁵¹ D. Lin, B. Xing, *Environ. Sci. Technol.* 42(19) (2008), 7254--7259
- ¹⁵² X. Wang, L. U. Jialong, B. Xing, *Environ. Sci. Technol.* 42(9) (2008), 3207-3219
- ¹⁵³ K. Yang, X. Wang, L. Zhu,, *Environ. Sci. Technol.* 40(18) (2006), 5804-5810
- ¹⁵⁴ B.A.F. Mibeck, E.S. Olson, S.J. Miller, *Fuel Processing Technology* 9(11) (2009), 1364-1371

-
- ¹⁵⁵ H.-H. Cho, B. Smith, K.A. Fairbrother, W.P. Ball, ACS National Meeting Book of Abstracts, 2008
- ¹⁵⁶ J. Chen, D. Zhu, C. Sun, Environ. Sci. Technol. 41(7) (2007), 2536-2541
- ¹⁵⁷ X. Li, G. H. Chen, Mater. Lett. 63 (2009), 930-932
- ¹⁵⁸ S.-Y. Oh, P.C. Chiu, Environ. Sci. Technol. 43(18) (2009), 6983-6988
- ¹⁵⁹ V.V. Molchanov, M.N. Shchuchkin, V.I. Zaikovskii, S.V. Bogdanof, N. A. Zaitseva, Kinetic and Catalysis 49(5) (2009) 702-707
- ¹⁶⁰ D. Zhu, S. Kvon, J.J. Pignatelo, Environ. Sci. Technol. 39(11) (2005), 3990-3998
- ¹⁶¹ D. Zhu, J.J. Pignatelo, Environ. Sci. Technol. 39(7) (2005), 2033-2041
- ¹⁶² J.J. Pignatello, Environ. Sci. Technol. 39(6) (2005), 1606-1615
- ¹⁶³ A.C. Ion, A. Alpatova, I. Ion, A. Culetu, Mat. Sci. Eng. B, 2011, doi: 10.1016/j.mseb.2011.01.018
- ¹⁶⁴ A.C. Ion, I. Ion, A. Culetu, Mat. Sci. Eng. B, 2010, doi: 10.1016/j.mseb.2010.07.021
- ¹⁶⁵ J. Chen, D. Zhu, C. Sun, Environ. Sci. Technol. 41(7) (2007), 2536-2541